

## HP03 Directional Control Valves

HP03 valves operate at high pressure and offer high flow capability in a very compact size. Flows to 15 U.S. gpm (57 L/min) are possible at pressures to 10 000 psi (700 bar).

These are very efficient valves featuring large flow passages for low pressure drop.

Typical pressure drop (open center spool) is a low 112 psi at 5 U.S. gpm (8 bar at 19 L/min) nominal flow.

Refer to pages 2 and 3 for a description of spools and operators.

### Mounting

Subplate, Special HP03 Pattern. Refer to page 3.

### Actuator Options

- 6100 Series: Manual Lever.
- 6500 Series: Direct Solenoid.
- 6800 Series: Hydraulic Piloted.
- 6900 Series: Air Piloted.

### Rated Flow

Nominal: 5 U.S. gpm (19 L/min).  
Maximum: 15 U.S. gpm (57 L/min).

### Rated Pressure

10 000 psi (700 bar).

### Tank Port Pressure (Maximum)

Manual Actuated Models:

3000 psi (210 bar).

Solenoid Actuated Models:

Standard, 3000 psi (210 bar).

Hydraulic and Air Actuated Models:

1500 psi (105 bar).

### Response Time (Full Stroke)

Solenoid Energized:

AC, 12 ms; DC, 20 ms.

Spring Returned:

AC, 15 ms; DC, 20 ms.

**HP03 SERIES**  
**5 gpm (19 L/min) Nominal**  
**15 gpm (57 L/min) Max**  
**10 000 psi (700 bar) Rated Pressure**



Table of Contents		
All Models	Internal Operators	Page 2
All Models	Spool Descriptions	Page 3
All Models	Mounting	Page 3
All Models	Performance	Page 4
6100 Series	Manual Lever Operated	Page 5
6500 Series	Solenoid Actuated	Page 6
6800 Series	Hydraulic Actuated	Page 9
6900 Series	Air Actuated	Page 9
All Models	Model Code	Page 10

## INTERNAL OPERATORS

The *Valve Operator* table shows available internal operators and the most common spools. Refer to *Typical Model Code* on page 10 to specify specific valve model.

Contact the Dynex Sales department for availability of spool options not shown.

The function symbols in the table show solenoid or lever actuated models as reference. Air and hydraulic actuators are also available.

Flow pattern in the center position or during crossover is determined by the selected spool. Refer to *Spool Descriptions* on page 3.

### Flow Patterns

Actuator "A" opens flow path (P→A).  
Actuator "B" opens flow path (P→B).  
The exception are models with Code 6 internal operators, which are centered when actuated.

Spring-centered and spring-offset models are spring-positioned unless actuated.

### Detented Models (Solenoid Operated)

Code 3 operators (two position detented) hold the spool in the last actuated position. These valves can be actuated momentarily (minimum electrical signal duration, 50 ms) to shift and hold the spool in that position.

### "R" Option

#### (Internal Operator Codes 4 & 6 Only)

Flow pattern can be altered with "R" (Reverse Assembly) option. Refer to *Valve Operator Descriptions* table for flow pattern details.

## APPLICATION NOTES

### Standard Seals

All valves use Fluorocarbon (Viton<sup>®</sup>, Fluorel<sup>®</sup>, or equivalent) o-rings, providing greater fluid compatibility and increased temperature range performance.

### Fluid Recommendations

50 to 1500 SUS (7 to 323 cSt) viscosity;  
-20° to 200° F (-29° to 93° C) temperature range.

### Recommended Filtration

Use filtration to provide fluid which meets these ISO Code 4406 cleanliness values: 19/17/14.

## Valve Operator Descriptions<sup>①</sup>

Internal Operator Code	Actuator, Operation	Spool Types	Operator Functions		
			Non-Actuated	Actuated	Function Symbol
1	Lever + Single Actuator, Two Position	0, (20) <sup>②</sup> or 1, (21) <sup>②</sup>	P→B	P→A	
2	Lever + Single Actuator, Two Position	0, (20) <sup>②</sup> or 1, (21) <sup>②</sup>	P→A	P→B	
3	Double Actuator, Two Position	0 or 1	Detented in Actuated Positions	P→A or P→B	
		03	Detented in Actuated Positions	P→A or P→B	
	Lever Actuator, Three Position	All Spools	Detented in Actuated Positions	P→A or P→B	
4	Single Actuator, Two Position	03	Spring Centered	P→A	
		03 Reverse	Spring Centered	P→B	
		011	Spring Centered	P→B	
		011 Reverse	Spring Centered	P→A	
		0, 1, 3	Spring Centered	P→A	
		0, 1, 3 Reverse	Spring Centered	P→B	
5	Lever + Double Actuator, Three Position	All Spools	Spring Centered	P→A or P→B	
6	Single Actuator, Two Position	03	P→B	Centered	
		03 Reverse	P→A	Centered	
		011	P→A	Centered	
		011 Reverse	P→B	Centered	
		0, 1, 3	P→B	Centered	
		0, 1, 3 Reverse	P→A	Centered	
7	Lever Operated, Two Position	0 or 1	Detented in Actuated Positions	P→A or P→B	

<sup>①</sup> A & B represent the actuator(s), which can be Air, Hydraulic, or Solenoid.

<sup>②</sup> Code 1 or 2 operators (other than Lever) use Type 20 or Type 21 spools. These spools provide the same function, but are not interchangeable with Type 0 or Type 1 spools. Lever models use Type 0 and 1 spools.

## Spool Descriptions<sup>①</sup>

Spool Types	Spool Symbol	Crossover Function	Description of Spool Function
0, (20) <sup>②</sup>			Closed center spool. All ports blocked in center position.
1, (21) <sup>②</sup>			Open center spool. All ports connected in center position. Allows fluid motors or cylinders to move when de-energized. Minimum shock during crossover.
3			Pressure port blocked in center position. Both A and B ports connected to tank.
4			A and B ports pressurized in center position, tank port blocked. Used for a differential circuit with single rod cylinder. Prevents motor cavitating when decelerating. Reduces crossover shock.
011			Tandem center spool, as noted for Type 01 and 56 spools, but with open crossover.
2			Open center spool with port B blocked and port A open to pressure and tank in the center position.
2R			Open center spool with port A blocked and port B open to pressure and tank in the center position.
32			Pressure port blocked with port A blocked, port B connected to tank in center position.
32R			Pressure port blocked with port B blocked, port A connected to tank in center position.
36			Pressure port blocked in center position. A and B ports partially restricted and connected to tank.
03			Closed center spool. All ports blocked in the center position. Tank port blocked in all positions.

① A & B represent the actuator(s), which can be Air, Hydraulic, or Solenoid.

② Code 1 or 2 operators (other than Lever) use Type 20 or Type 21 spools. These spools provide the same function, but are not interchangeable with Type 0 or Type 1 spools. Lever models use Type 0 and 1 spools.

## SPECIAL VALVE MOUNTING

Valves can be mounted without removing nameplate. Mounting position is unrestricted for all valves.

Although similar to standard NFPA D03, NG6 ISO 4401-03 valves in size, HP03 valves require a special high pressure mounting pattern. The mounting surface drawing shows the minimum flush or raised surface required for the HP03 pattern.

Port o-rings are included with valves.

Mounting bolts must be ordered separately: .250-20 UNC. Threaded x 0.75 inch (19 mm), Grade 8 or better, four required. Recommended mounting torque is 12 lb-ft (16 N·m).

**Note:** Installation drawing dimensions are shown in inches (millimeters in parentheses) and are nominal.

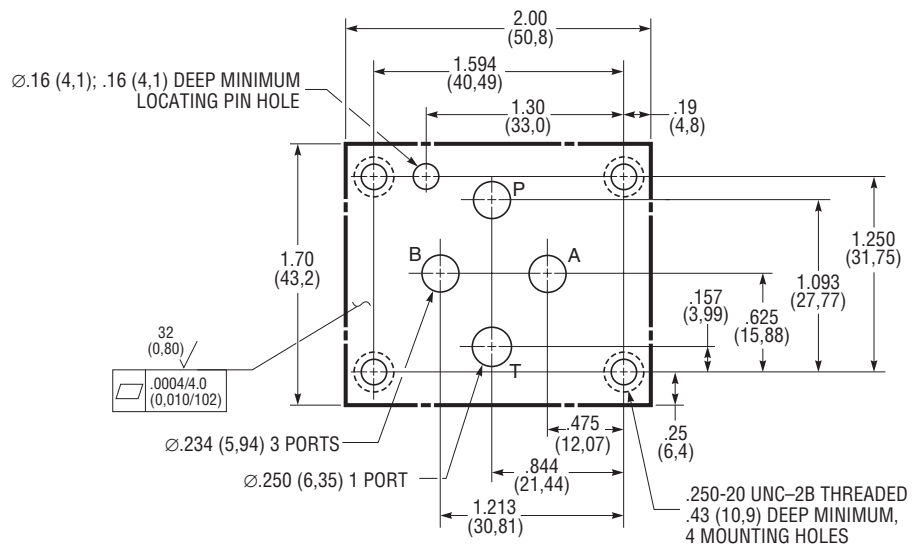

Minimum Mounting Surface, Special HP03 Pattern

## VALVE EFFICIENCY

HP03 valves provide exceptionally low pressure drop, as shown in the performance curves.

### Determining Pressure Drop

The *Pressure Drop ( $\Delta P$ ) Curves* show typical resistance to flow for various spool types. The *Flow Curve Reference* table identifies the typical pressure drop curve for desired spool and flow path.

If the valve has simultaneous flow through it in more than one direction, then the "Loop" pressure drop should be determined to estimate total pressure drop ( $\Delta P$ ) through the valve.

To determine total "Loop" drop, the individual pressure drops for both flow paths (for example: P→A + B→T) must be added together.

## Pressure Drop ( $\Delta P$ ) Curves<sup>①</sup>

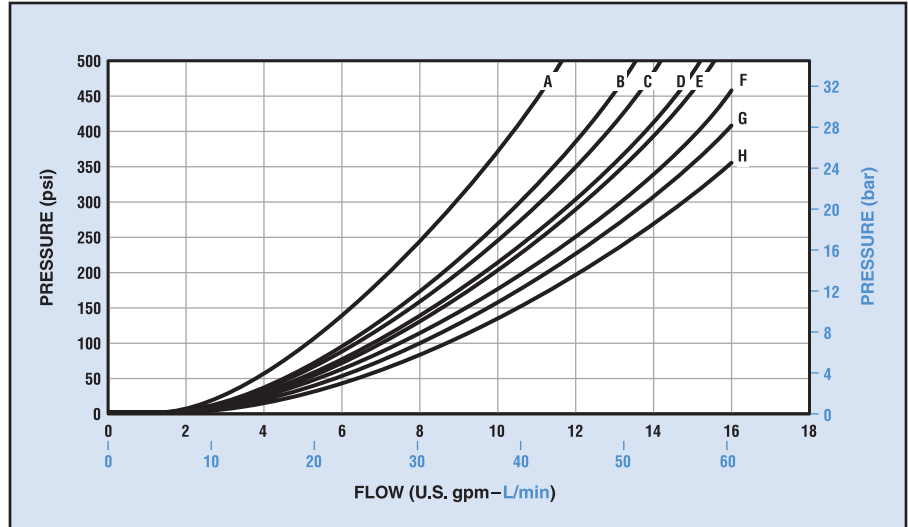

<sup>①</sup> Curves are based on the use of 100 SUS (20 cSt) petroleum-based fluid at 120° F (50° C).

## Flow Curve Reference

Flow Path	Spool Types <sup>①</sup>												
	0	20	1	21	3	4	011	2	2R	32	32R	36	03
P→A	B	B	D	E	B	D	C	C	B	B	B	B	B
P→B	B	B	D	E	B	D	C	C	B	B	B	B	B
A→T	E	E	G	G	H	E	E	E	E	E	E	E	—
B→T	E	E	G	G	H	E	E	E	E	E	E	E	—
P→T	—	—	D	D	—	—	A	A	—	—	—	—	—

<sup>①</sup> See *Spool Descriptions and Symbols* on page 3 to determine which spool to select for valve application.

## Typical Pressure Drop ( $\Delta P$ Example)

To determine the pressure drop ( $\Delta P$ ) for Spool Type "0"

From *Flow Curve Reference* table, cross reference:

**Spool Type "0"** with the **Flow Path** for P→A or P→B functions = **(B curve)**

**Spool Type "0"** with the **Flow Path** for A→T or B→T functions = **(E curve)**

From *Pressure Drop ( $\Delta P$ ) Curves*:

At 5 gpm: **(B curve)** = approx. **65 psi** (P→A)

At 5 gpm: **(E curve)** = approx. **47 psi** (B→T)

To determine total (for example: P→A + B→T):

**Loop Pressure Drop** = 65 psi + 47 psi = **112 psi**

## 6100 SERIES MANUAL LEVER OPERATED MODELS

Manual models feature a hand lever that can be configured on either end of valve. To specify lever orientation, refer to *Typical Model Code* on page 10.

Most manual models are rated for 15 U.S. gpm (57 L/min) maximum. The exceptions are noted in the table *Lever Actuated Flow Limitations* below.

### Weight (Mass)

3.5 lb (1,6 kg).

## Pressure Drop ( $\Delta P$ ) – Manual Lever Models<sup>①</sup>

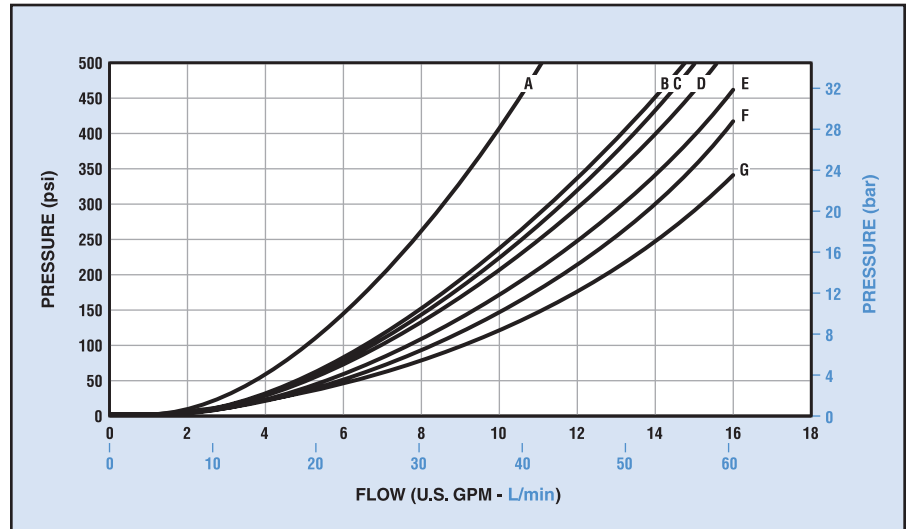

<sup>①</sup> Curves are based on the use of 100 SUS (20 cSt) petroleum-based fluid at 120° F (50° C).

## Lever Actuated Flow Limitations

Operator Code	Spool Types	Maximum Flow	
		U.S. gpm	L/min
1 and 2	0	7.0	26
	1	8.0 <sup>①</sup>	30 <sup>①</sup>
	03	7.0	26
3	1	8.0 <sup>①</sup>	30 <sup>①</sup>
	011	7.5	28
	2 or 2R	7.5	28
5	1	8.0 <sup>①</sup>	30 <sup>①</sup>
7	1	8.0 <sup>①</sup>	30 <sup>①</sup>

<sup>①</sup> 8 U.S. gpm (30 L/min) maximum at 10 000 psi (700 bar). Flow capacity increases at reduced pressure; i.e. 11 U.S. gpm (41 L/min) at 2000 psi (140 bar).

## Flow Curve Reference

Flow Path	Spool Types <sup>①</sup>										
	0	1	3	4	011	2	2R	32	32R	36	03
P→A	B	C	B	C	B	B	B	B	B	B	B
P→A	B	C	B	C	B	B	B	B	B	B	B
P→A	F	G	G	F	D	D	D	F	F	F	–
P→A	E	G	G	F	D	D	D	F	F	F	–
P→T	–	B	–	–	A	A	A	–	–	–	–

<sup>①</sup> See Spool Descriptions and Symbols on page 3 to determine which spool to select for valve application.

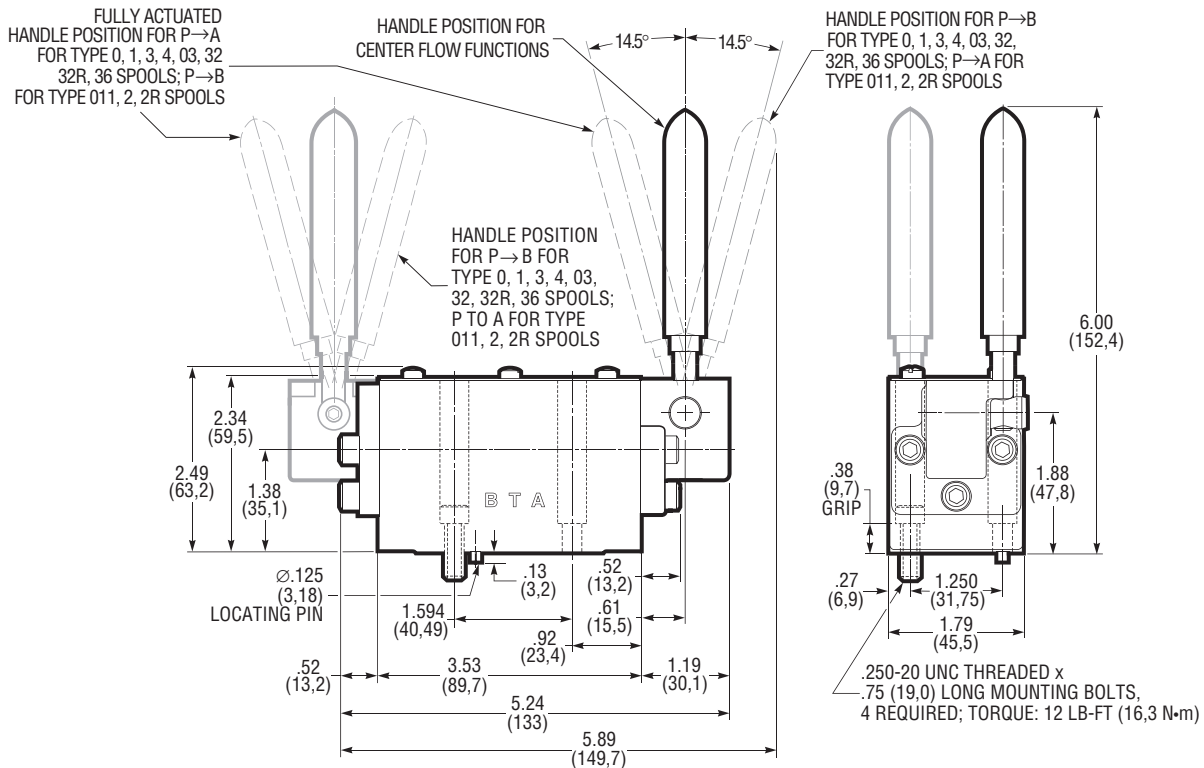

6100 Series, Manual Lever Operated

## 6500 SERIES SOLENOID MODELS

### Valve Flow Capacity

Flow capacity depends on valve actuator, internal operator and spool type. Refer to *Typical Model Code* on page 10.

Curves show typical performance for each spool type. The letters in the *Flow Curve Reference* table identify the appropriate curve.

### Flow Capacity – Solenoid Models

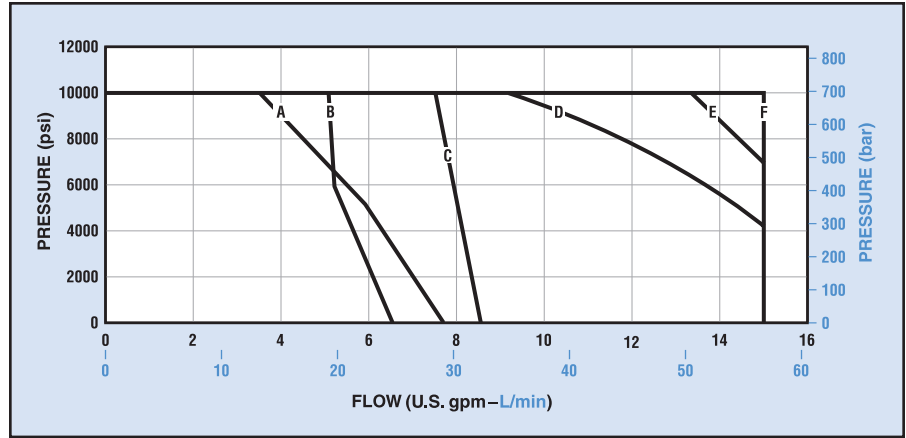

① Curves are based on the use of 100 SUS (20 cSt) petroleum-based fluid at 120° F (50° C).

### Flow Curve Reference

Operator Code	Spool Types												
	0	20	1	21	3	4	011	2	2R	32	32R	36	03
1 and 2	-	E	-	F	-	-	-	-	-	-	-	-	-
3	B	-	F	-	-	-	-	-	-	-	-	-	F
4 and 5	F	-	F	-	F	F	A	A	A	F	F	F	F
6	F	-	F	-	F	F	C	C	C	F	F	F	D

## HP03 SUBPLATE AND BOLT KITS

Part Number	Description
<i>Subplates:</i>	
PSO29-HP03-SAE6	Side Ports, No. 6 SAE
PSO29-HP03-BSP6	Side Ports, G 3/8 (BSPP)
PSO30-HP03-.56MP <sup>①</sup>	Side Ports, 9/16" Medium Pressure Coned and Threaded
<i>Mounting Bolts:</i>	
P11-BK	Four .250-20 UNC Threaded x 0.75 inches (19,0 mm)

① A, B, and P ports fit Medium Pressure Coned and Threaded (Autoclave, Butech, or equivalent fitting).

## SOLENOID OPTIONS

Models are available with standard AC or DC solenoids.

### Electrical Connections

Plug-In-Terminal Solenoids fit Deutsch DT04-2P Connector or EN175301-803/ DIN 43650 Form A (Hirschmann Type) Connector.

### Standard Solenoids

Solenoids are easily removed without manual wiring or opening the hydraulic system for replacement. Coils can be rotated 360° for flexible installation.

### CSA/UL Recognized

All Solenoid coils are printed with the symbol:



(CSA and UL recognized component).

## Solenoid Electrical Data

Solenoid Types	Volts	Frequency (Hz) <sup>①</sup>	Coil Resistance (Ohms) at 77° F (25° C)	Power (Watts)
AC Standard	24AC	60	19.4 - 21.4	23
	115AC	60	444 - 492	23
	230AC	60	1823 - 1941	23
DC Standard	12DC	—	4.56 - 5.04	30
	24DC	—	18.24 - 20.16	30
Explosion Proof	115AC	60	830.4 - 900.0	13
	24DC	—	44.3 - 46.1	13

① Information shown is for 60Hz models only. At other frequencies the coil characteristics must be revised.

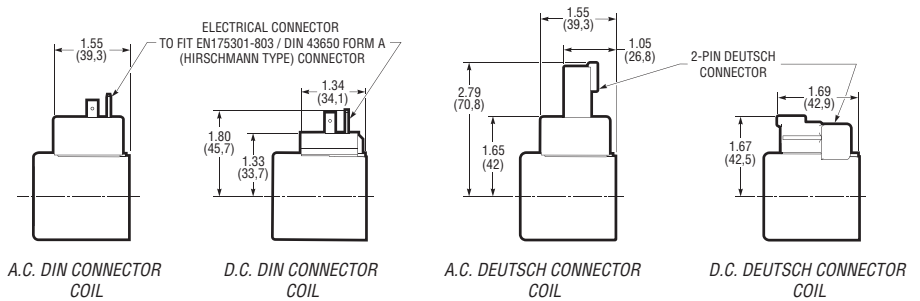

## Solenoid Model Dimensions

### Weight (Mass)

Single Solenoid:  
3.85 lb (1,8 kg).

Double Solenoid:  
5.80 lb (2,6 kg).

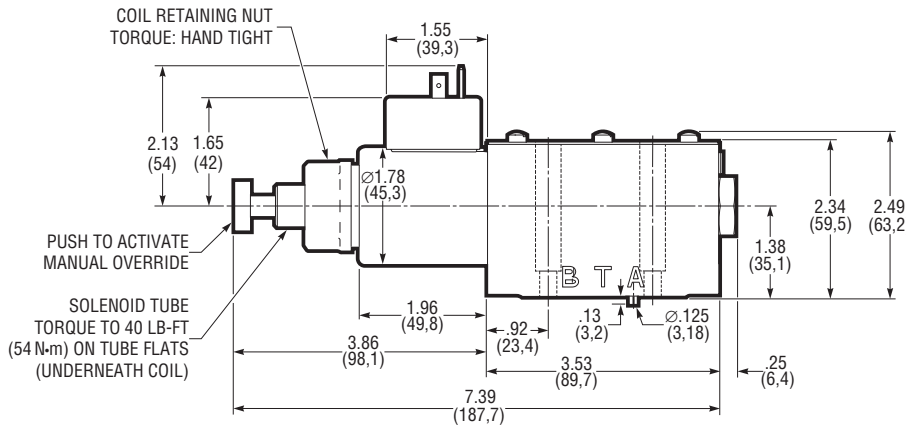

6500 Series, Single Solenoid Models (A.C. DIN Connector Version Shown)

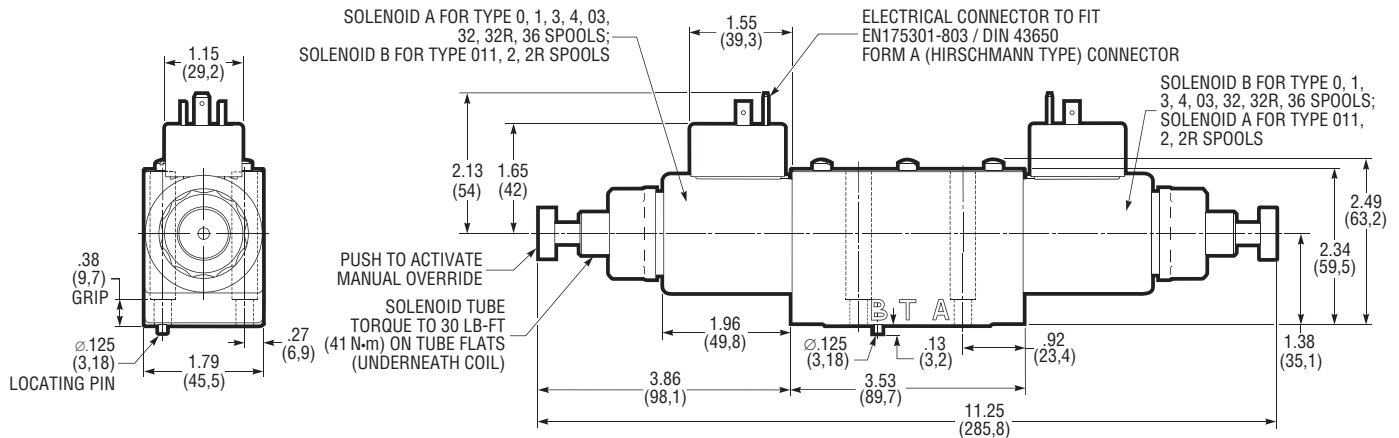

6500 Series, Double Solenoid Models (A.C. DIN Connector Version Shown)

# EXPLOSION PROOF SOLENOID MODELS

“EP” solenoids with special enclosures are approved by UL and CSA for use in hazardous locations.



Conforms to ANSI/ISA STD 60079-31, UL STDS 1203, 50, 50E, 60079-0 & 60079-1. Certified to CAN/CSA STD C22.2 Nos. 30, 25, 0.4, 0.5, 60079-0, 60079-1 & 60079-31.

## Explosion Proof Solenoid Ratings

Location	Governing Standard	Gas Ratings	Dust Ratings
United States	NEC 500	Class I (Division 1) Group A, B, C, D, T4	Class II & III (Division 1) Group E, F, G, T4
<i>Safety ratings in the US are governed under the National Electrical Code (NEC). There are two separate classification systems (NEC 500 and NEC 505). To ensure universal acceptance, MSA HAZ-LOC coils have been approved under both systems.</i>			
United States	NEC 505	Class I (Zone 1) AEx d IIC T4 Gb	Class II (Zone 21) AEx tb IIIC T4 Db
<i>Mandatory for Gulf of Mexico Class and Zone Rating. Most International markets require recognition under the International Electrotechnical Committee (IEC) Ex scheme.</i>			
Canada	CEC/CSA	Ex d IIC T4 Gb (Zone 1)	Ex tb IIIC T4 Db (Zone 21)
<i>Canadian safety ratings are regulated by the Canadian Electrical Code (CEC), closely following the US-NEC Standards. Similar to NEC 500, NEC 505 and ATEX Gas and Dust ratings.</i>			
Europe	ATEX	II 2 G   EX d IIC T4 Gb (Zone 1)	II 2 D   EX tb IIIC T4 Db (Zone 21)
<i>Similar to NEC 505 Gas and Dust ratings.</i>			
International	IECEx	Ex d IIC T4 Gb (Zone 1)	Ex tb IIIC T4 Db (Zone 21)
<i>Similar to ATEX Gas and Dust ratings.</i>			

## Explosion Proof Solenoid Dimensions

### Weight (Mass)

Single Solenoid: 6.78 lb (3,1 kg).

Double Solenoid: 11.66 lb (5,3 kg).

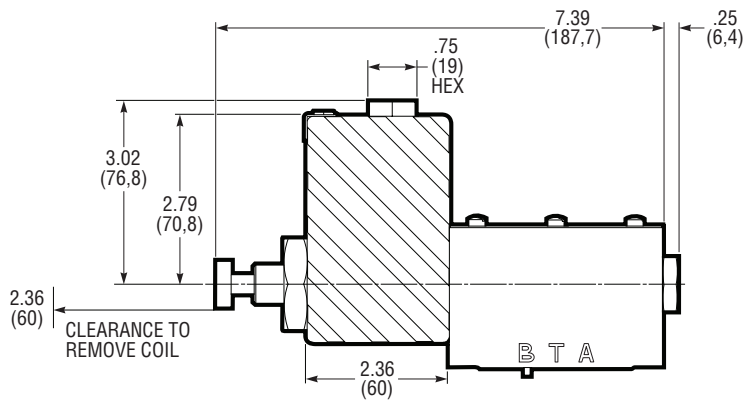

6500 Series, Single AC/DC “EP” Explosion Proof Solenoid Models

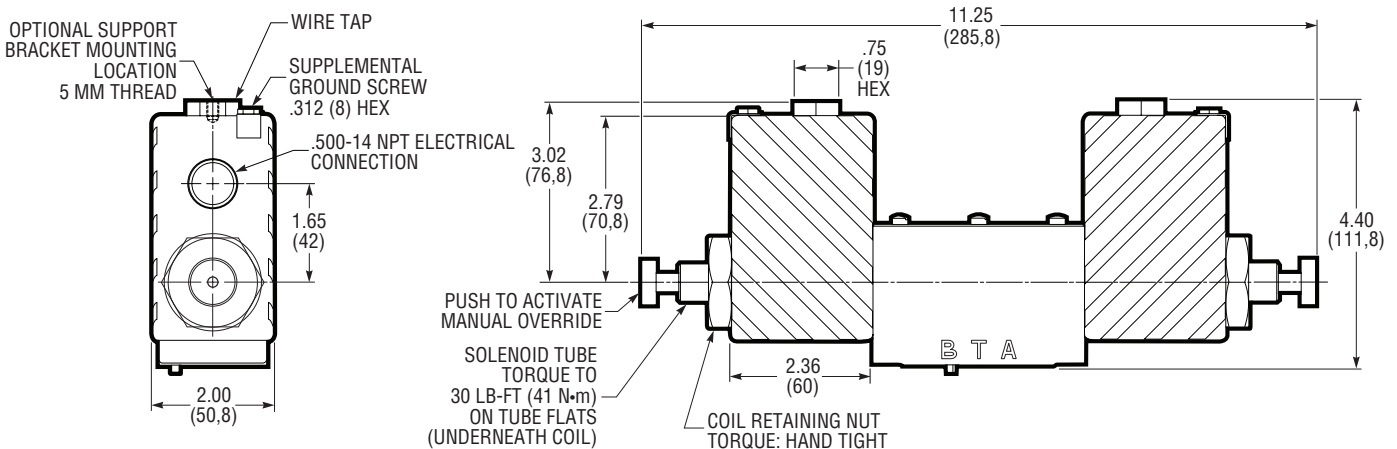
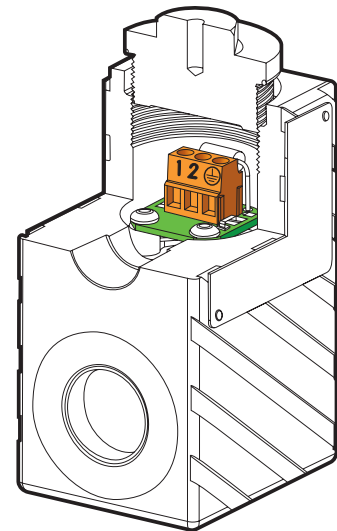

6500 Series, Double AC/DC “EP” Explosion Proof Solenoid Models





# TYPICAL MODEL CODE

6 1 1 0 - HP03-115DA - R - A12 - E - 4 0

Valve Type	
6	Subplate Mounted Directional Control

Actuators	
1	Lever Operated
5	Solenoid Actuated
8	Hydraulic Actuated
9	Air Actuated

Internal Operators	
1	Two Position: Spring Offset (P→B), <sup>①</sup> Actuated Position (P→A)
2	Two Position: Spring Offset (P→A), <sup>①</sup> Actuated Position (P→B)
3	Two Position: Detented; <sup>②</sup> Three Position: Detented (Lever Operated Only)
4	Two Position: Spring Centered, Actuated Position (P→A) <sup>③④</sup>
5	Three Position: Spring Centered
6	Two Position: Spring Offset (P→B), <sup>③⑤</sup> Actuator Centered
7	Two Position: Detented (Lever Operated Only)

① Only available with Type 20 or 21 spools (Type 0 or 1 for Lever Operated model).  
 ② Only available with Type 0, 1, and 03 spools.  
 ③ Not available with Lever Operated valves.  
 ④ Spool Type 011 (tandem center) actuated Position P→B.  
 ⑤ Spool Type 011 (tandem center) spring offset P→A.

Spool Types			
0, (20) <sup>①</sup>		2 <sup>②</sup>	
1, (21) <sup>①</sup>		2R <sup>②</sup>	
3 <sup>②</sup>		32 <sup>②</sup>	
4 <sup>②</sup>		32R <sup>②</sup>	
011 <sup>②</sup>		36 <sup>②</sup>	
		03	

① Code 1 or 2 operators (other than Lever) use Type 20 or Type 21 spools. These spools provide the same function, but are not interchangeable with Type 0 or Type 1 spools. Lever Operated models use Type 0 and 1 spools.  
 ② Not available with Type 3 Internal Operators (except Lever Operated models).

Modification Number

Design Number

Seals	
No Code	Fluorocarbon (Viton® or Fluorel®)
E	EPR (Ethylene-Propylene Rubber)

Lever Position (Manual Models Only)	
A12	12 o'clock position, port "A" end
A3	3 o'clock position, port "A" end
A6	6 o'clock position, port "A" end
A9	9 o'clock position, port "A" end
B12	12 o'clock position, port "B" end
B3	3 o'clock position, port "B" end
B6	6 o'clock position, port "B" end
B9	9 o'clock position, port "B" end

Reverse Assembly Option	
R	Used with <i>Internal Operators</i> Codes 4 & 6 only. Refer to <i>Valve Operator Descriptions</i> on page 2 for details.

Electrical Options			
AC Solenoids Deutsch Connector: <sup>①</sup>		DC Solenoids Deutsch Connector: <sup>①</sup>	
115DA	115V/60Hz, 110V/50Hz	12DD	12VDC
230DA	230V/60Hz, 220/50Hz	24DD	24VDC
24DA	24V/60Hz, 24V/50Hz		
AC Solenoids DIN Connector: <sup>②</sup>		DC Solenoids DIN Connector: <sup>②</sup>	
115HA	115V/60Hz, 110V/50Hz	12HD	12VDC
230HA	230V/60Hz, 220/50Hz	24HD	24VDC
24HA	24V/60Hz, 24V/50Hz		
AC Explosion Proof: <sup>③</sup>		DC Explosion Proof: <sup>③</sup>	
115EP	115V/60Hz, 110V/50Hz	24 EP	24VDC

① Fits Deutsch DT04-2P Connector.  
 ② Fits EN175301-803 / DIN 43650 Form A (Hirschmann Type) Connector.  
 ③ Junction box with 1/2" NPT entry. Terminal strip connection.

Valve Size	
HP03	High Pressure Special Mounting Pattern

*Specifications shown were in effect when printed. Since errors or omissions are possible, contact your Sales representative or the Sales department for the most current specifications before ordering. Dynex reserves the right to discontinue products or change designs at any time without incurring any obligation.*

[www.dynexhydraulics.com](http://www.dynexhydraulics.com)

**USA Headquarters**

770 Capitol Drive  
Pewaukee, WI 53072  
Tel: +1 (262) 691-2222  
FAX: +1 (262) 691-0312  
sales@dynexhydraulics.com

**Power Units & Systems**

54 Nickerson Road  
Ashland, MA 01721  
Tel: +1 (508) 881-5110  
ashland@dynexhydraulics.com

**European Sales**

Unit C5 Steel Close, Little End Road,  
Eaton Socon, St Neots,  
Cambs. PE19 8TT United Kingdom  
Tel:+44 (0) 1480 213980 FAX:+44 (0) 1480 405662  
sales@dynexhydraulics.co.uk